

Operation Manual

Vacuum Pump V-80 / V-180



Imprint

Product Identification:
Operation Manual (Original) Vacuum Pump V-80 / V-180
11594501

Publication date: 03.2024

Version A

BÜCHI Labortechnik AG
Meierseggrasse 40
Postfach
CH-9230 Flawil 1
E-Mail: quality@buchi.com

BUCHI reserves the right to make changes to the manual as deemed necessary in the light of experience, especially with respect to structure, illustrations and technical details.

This manual is copyrighted. Information from it may neither be reproduced, distributed, or used for competitive purposes, nor made available to third parties. The manufacture of any component with the aid of this manual without prior written agreement is also prohibited.

Table of contents

1	About this document.....	5
1.1	Mark-ups and symbols.....	5
1.2	Trademarks.....	5
1.3	Connected instruments.....	5
2	Safety.....	6
2.1	Intended use.....	6
2.2	Use other than that intended.....	6
2.3	Staff qualification.....	6
2.4	Personal protective equipment.....	7
2.5	Warning notices in this document.....	7
2.6	Warning symbols.....	7
2.7	Residual risks.....	8
	2.7.1 Faults during operation.....	8
	2.7.2 Hot surfaces.....	8
	2.7.3 Dangerous particles.....	9
	2.7.4 Dangerous vapors.....	9
	2.7.5 Glass breakage.....	9
2.8	Modifications.....	9
3	Product description.....	10
3.1	Description of function.....	10
3.2	Configuration.....	10
	3.2.1 Overview.....	10
	3.2.2 Front view.....	11
	3.2.3 Rear view.....	12
	3.2.4 Connections.....	13
	3.2.5 Internal view.....	14
3.3	Scope of delivery.....	14
3.4	Type plate.....	14
3.5	Technical data.....	15
	3.5.1 Vacuum Pump.....	15
	3.5.2 Ambient conditions.....	16
	3.5.3 Materials.....	16
	3.5.4 Installation site.....	17
4	Transport and storage.....	18
4.1	Transport.....	18
4.2	Storage.....	18
4.3	Lifting the instrument.....	18
5	Installation.....	19
5.1	Before installation.....	19
5.2	Stacking the instrument.....	19
5.3	Connecting the instrument.....	20
5.4	Installing the Interface I-80 / I-180.....	21
5.5	Connecting the BUCHI communication cable.....	21
5.6	Accessories.....	22
	5.6.1 Installing the Woulff bottle.....	22
	5.6.2 Connecting the Woulff bottle.....	23
	5.6.3 Installing the secondary condenser.....	24
	5.6.4 Connecting cooling to the secondary condenser.....	26
5.7	Securing against earthquakes.....	27
5.8	Establishing electrical connections.....	28

6	Operation	29
6.1	Operating without an interface.....	29
6.2	Operating with an interface.....	29
7	Cleaning and servicing	31
7.1	Maintenance work.....	31
7.2	Cleaning the housing	31
7.3	Cleaning the pump.....	31
7.4	Cleaning the pump after working with strong acids	32
7.5	Cleaning check valves, membranes and center tube	32
7.6	Cleaning the secondary condenser	33
7.7	Cleaning the Woulff bottle.....	33
7.8	Inspecting and replacing the seals	33
7.9	Inspecting and replacing the hoses	33
7.10	Servicing the instrument	34
8	Help with faults	38
8.1	Troubleshooting	38
	8.1.1 Customer service	38
9	Taking out of service and disposal	39
9.1	Taking out of service.....	39
9.2	Disposal	39
9.3	Returning the instrument	39
10	Appendix	40
10.1	Spare parts and accessories	40
	10.1.1 Spare parts	40
	10.1.2 Wear parts	41
	10.1.3 Accessories.....	44

1 About this document

This operation manual is applicable for all variants of the instrument. Read this operation manual before operating the instrument and follow the instructions to ensure safe and trouble-free operation.

Keep this operation manual for later use and pass it on to any subsequent user or owner.

BÜCHI Labortechnik AG accepts no liability for damage, faults and malfunctions resulting from not following this operation manual.

If you have any questions after reading this operation manual:

- ▶ Contact BÜCHI Labortechnik AG Customer Service.

<https://www.buchi.com/contact>

1.1 Mark-ups and symbols



NOTE

This symbol draws attention to useful and important information.

- ☑ This character draws attention to a requirement that must be met before the instructions below are carried out.
- ▶ This character indicates an instruction that must be carried out by the user.
- ⇒ This character indicates the result of a correctly carried out instruction.

Mark-up	Explanation
<i>Window</i>	Software Windows are marked-up like this.
<i>Tab</i>	Tabs are marked-up like this.
<i>Dialog</i>	Dialogs are marked-up like this.
<i>[Button]</i>	Buttons are marked-up like this.
<i>[Field names]</i>	Field names are marked-up like this.
<i>[Menu / Menu item]</i>	Menus or menu items are marked-up like this.
Status	Status is marked-up like this.
Signal	Signals are marked-up like this.

1.2 Trademarks

Product names and registered or unregistered trademarks that are used in this document are used only for identification and remain the property of the owner in each case.

1.3 Connected instruments

In addition to this operation manual, follow the instructions and specifications in the documentation for the connected instruments.

2 Safety

2.1 Intended use

The instrument is designed as an item of laboratory equipment. The intended use is the evacuation of laboratory equipment. This is done by a PTFE-diaphragm pump with or without regulation by a vacuum controller.

The instrument can be used in laboratories for the following applications:

- Evacuating distillation instruments, like rotary evaporators (Rotavapor®)
- Vacuum filtration
- Vacuum-drying cabinets
- Drying ovens

2.2 Use other than that intended

Use of any kind other than that described in the section Chapter 2.1 "Intended use", page 6 and any application that does not comply with the technical specifications (see Chapter 3.5 "Technical data", page 15) constitutes use other than that intended.

In particular, the following applications are not permissible:

- Use of the device in an environment with a potential risk of explosion or areas which require explosion-safe apparatus
- Pumping of liquids and solid particles
- Processing of substances that can lead to spontaneous reactions, e.g. explosives, metal hydrides or solvents that can form peroxides
- Use for analysis (e.g. Kjeldahl)
- Generation of positive pressure (pressurizing a system)
- Operation at ambient temperatures >40 °C

Damage or hazards attributable to use of the product other than as intended are entirely at the risk of the user alone.

2.3 Staff qualification

Unqualified persons are unable to identify risks and are therefore exposed to greater dangers.

The instrument must be operated by suitably qualified laboratory staff.

The instrument must be commissioned and serviced by suitably qualified technicians.

These operating instructions are aimed at the following target groups:

Users

The users are persons that meet the following criteria:

- They have been instructed in the use of the instrument.
- They are familiar with the contents of these operating instructions and the applicable safety regulations and apply them.
- They are able, on the basis of their training or professional experience, to assess the risks associated with the use of the instrument.

Operator

The operator (generally the laboratory manager and qualified technicians) are responsible for the following aspects:

- The instrument must be correctly installed, commissioned, operated and serviced.
- Only suitably qualified staff must be assigned the task of performing the operations described in these operating instructions.
- The staff must comply with the local applicable requirements and regulations for safe and hazard-conscious working practices.
- Safety-related incidents that occur while using the instrument should be reported to the manufacturer (quality@buchi.com).

BUCHI service technicians

Service technicians authorized by BUCHI have attended special training courses and are authorized by BÜCHI Labortechnik AG to carry out special servicing and repair measures.

2.4 Personal protective equipment

Depending on the application, hazards due to heat and/or corrosive chemicals may arise.

- ▶ Always wear appropriate personal protective equipment such as safety goggles, protective clothing and gloves.
- ▶ Make sure that the personal protective equipment meets the requirements of the safety data sheets for all chemicals used.



2.5 Warning notices in this document



Warning notices warn you of dangers that can occur when handling the instrument. There are four danger levels, each identifiable by the signal word used.

Signal word	Meaning
DANGER	Indicates a danger with a high level of risk which could result in death or serious injury if not prevented.
WARNING	Indicates a danger with a medium level of risk which could result in death or serious injury if not prevented.
CAUTION	Indicates a danger with a low level of risk which could result in minor or medium-severity injury if not prevented.
NOTICE	Indicates a danger that could result in damage to property.

2.6 Warning symbols

The following warning symbols are displayed in this operation manual or on the instrument.

Symbol	Meaning
	General warning
	Instrument damage
	Dangerous electrical voltage

Symbol	Meaning
	Hot surface
	Hand injuries

Location of the warning symbols on the instrument

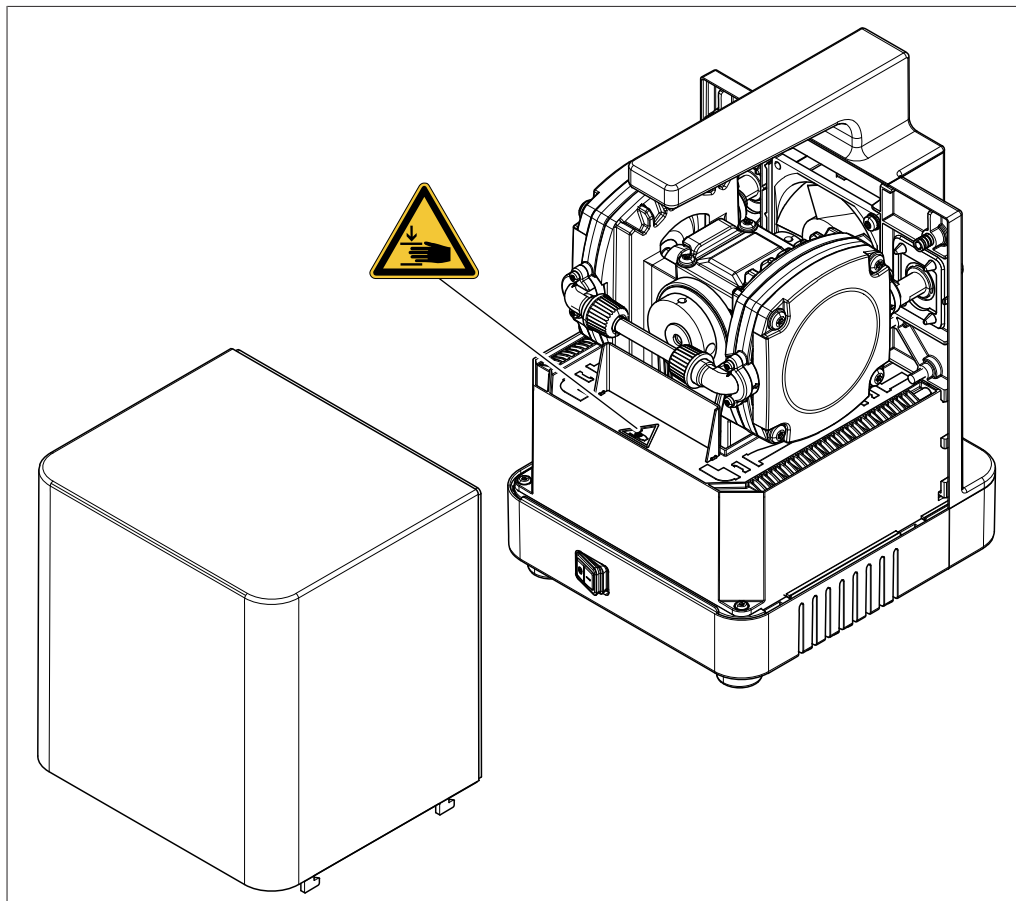

2.7 Residual risks

The instrument has been developed and manufactured using the latest technological advances. Nevertheless, risks to persons, property or the environment can arise if the instrument is used incorrectly.

Appropriate warnings in this manual serve to alert the user to these residual dangers.

2.7.1 Faults during operation

If an instrument is damaged, sharp edges, glass splinters, moving parts or exposed electrical wires can cause injuries.

- ▶ Regularly check instruments for visible damage.
- ▶ If faults occur, switch off the instrument immediately, unplug the power cord and inform the operator.
- ▶ Do not continue to use instruments that are damaged.

2.7.2 Hot surfaces

The surfaces of the instrument can become hot. If touched they can cause skin burns.

- ▶ Do not touch hot surfaces or wear suitable protective gloves.

2.7.3 Dangerous particles

The use of the instrument can produce dangerous particles that can cause life-threatening toxic effects.

- ▶ Observe the safety data sheets for all substances used.
- ▶ Do not process any unknown substances.
- ▶ Do not inhale any particles produced during processing.
- ▶ Ensure that particles are removed by a suitable fume hood.
- ▶ Only use the instrument in well ventilated areas.
- ▶ If particles escape from connections, check the seals concerned and replace them if necessary.

2.7.4 Dangerous vapors

The use of the instrument can produce dangerous vapors that are capable of causing life-threatening toxic effects.

- ▶ Do not inhale any vapors produced during processing.
- ▶ Ensure that vapors are removed by a suitable fume hood.
- ▶ Only use the instrument in well ventilated areas.
- ▶ If vapors escape from connections, check the seals concerned and replace them if necessary.
- ▶ Do not process any unknown fluids.
- ▶ Observe the safety data sheets for all substances used.

2.7.5 Glass breakage

Broken glass can cause severe cuts.

Minor damage to the ground joints impairs the sealing effect and may therefore diminish suction capacity.

- Handle the glass components carefully and do not drop them.
- Always place the glassware in a suitable holder when they are not in use.
- Always visually inspect glass components for damage every time they are to be used.
- Do not continue to use glass components that are damaged.
- Always wear protective gloves when disposing of broken glass.

2.8 Modifications

Unauthorized modifications can affect safety and lead to accidents.

- ▶ Use only genuine BUCHI accessories, spare parts and consumables.
- ▶ Carry out technical changes only with prior written approval from BUCHI.
- ▶ Only allow changes to be made by BUCHI service technicians.

BUCHI accepts no liability for damage, faults and malfunctions resulting from unauthorized modifications.

3 Product description

3.1 Description of function

The instrument is intended for evacuating laboratory apparatus to a terminal vacuum. It can be operated as a standalone instrument or combined with optional accessories. If the instrument is switched on, it runs in continuous mode unless it is connected to a BUCHI interface. In unregulated continuous mode, the pump runs at a maximum speed and generates a terminal vacuum. The time required for evacuation depends on the size (volume) of the vessel.

3.2 Configuration

3.2.1 Overview

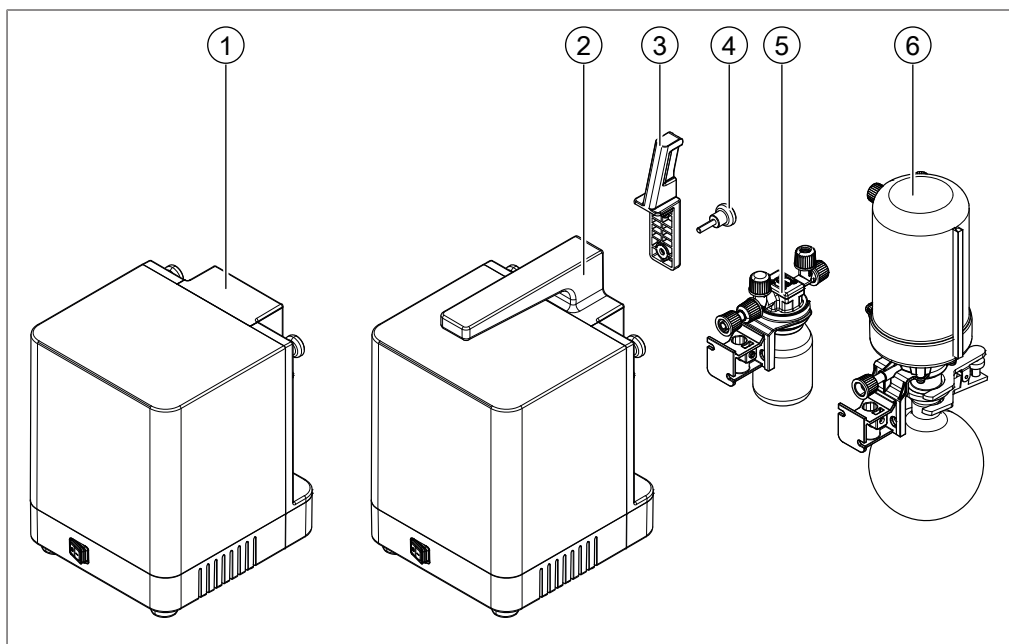

1 Vacuum Pump V-80

2 Vacuum Pump V-180

Optional

3 Interface holder

4 Knurled-head screw

5 Woulff bottle

6 Secondary condenser

3.2.2 Front view

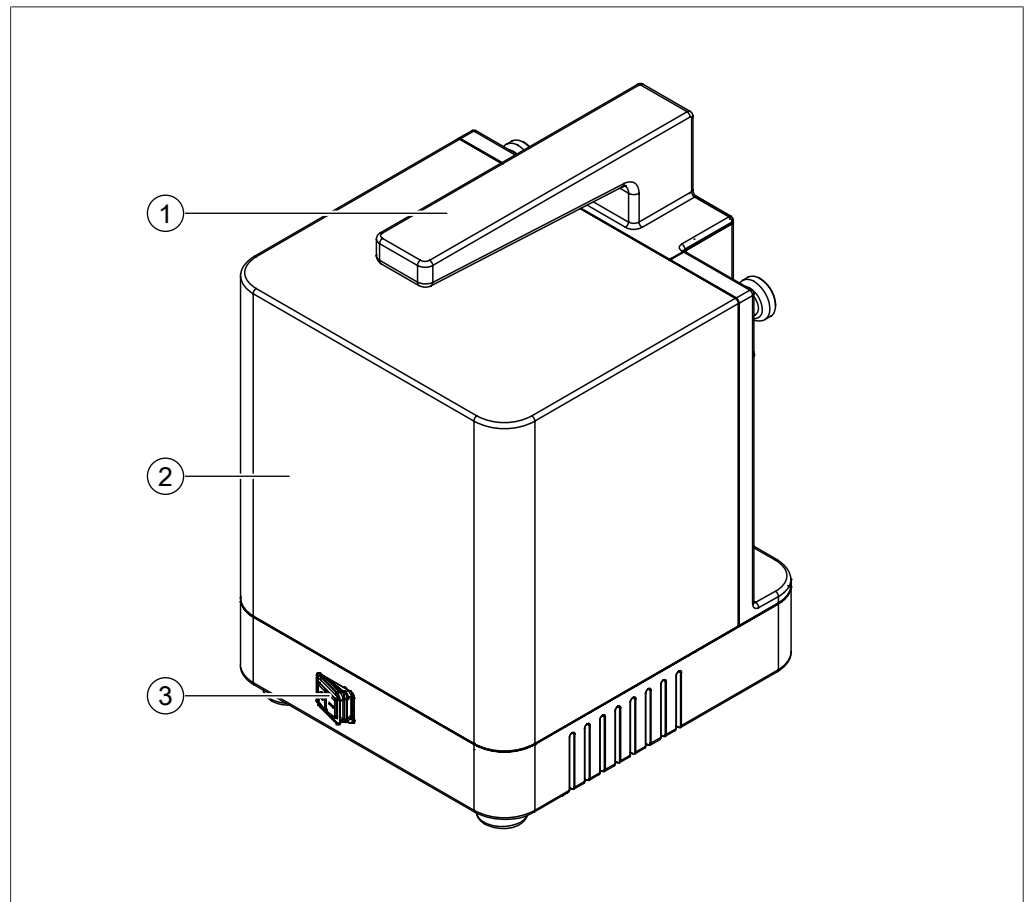

- 1 Carrying handle
(only Vacuum Pump V-180)
- 3 Main switch

- 2 Pump top cover

3.2.3 Rear view

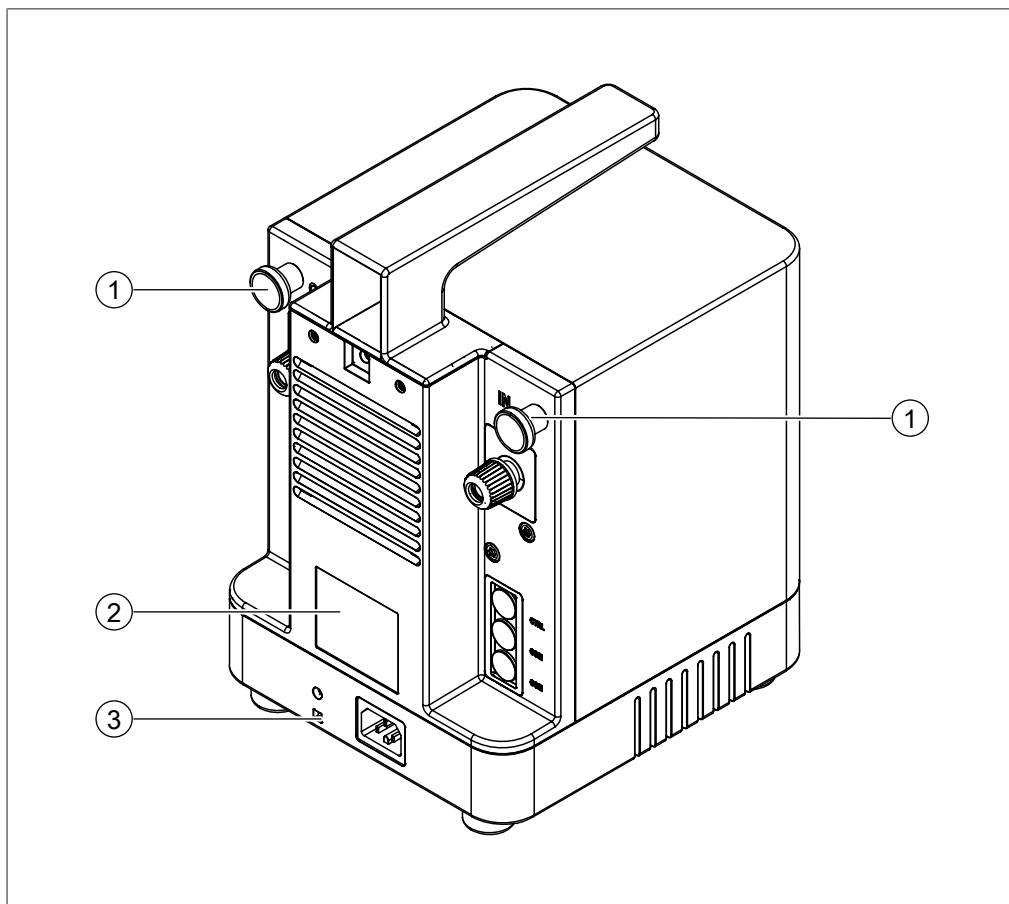

- | | | | |
|---|---|---|------------|
| 1 | Knurled-head screw | 2 | Type plate |
| 3 | Lashing eye
(for securing against earthquakes) | | |

3.2.4 Connections

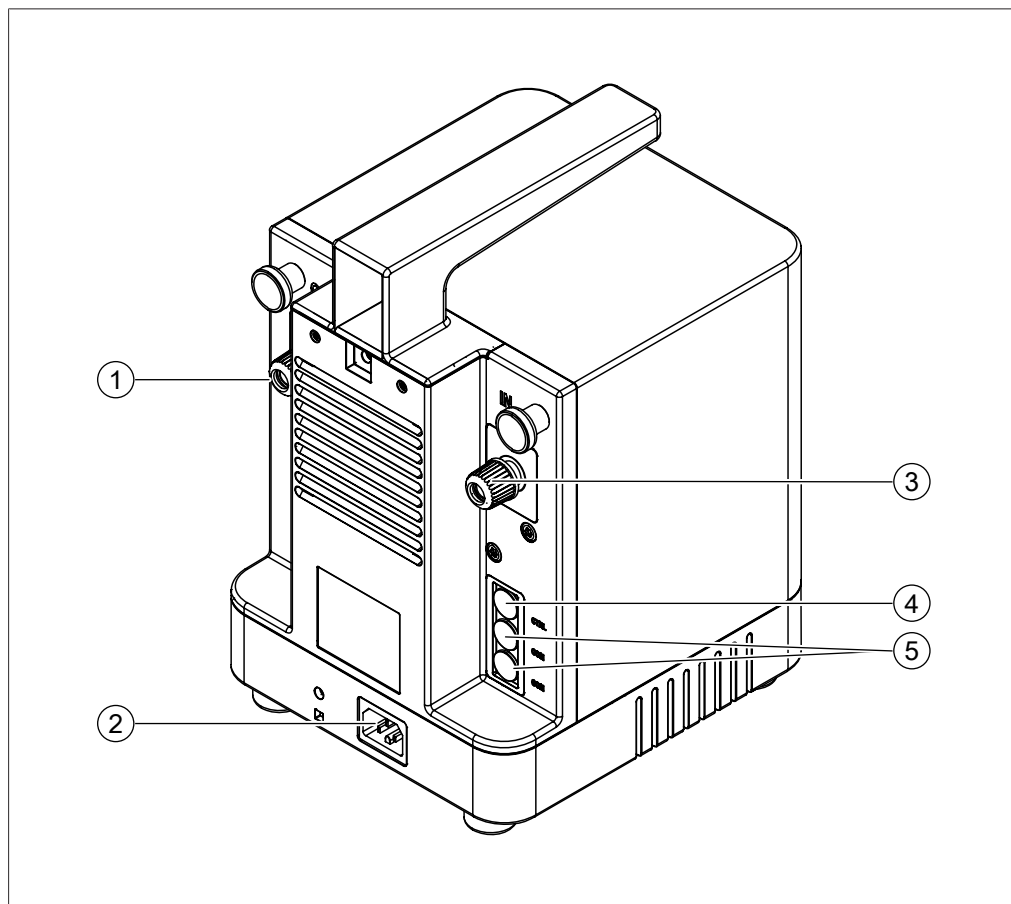

1 Pump **OUT**

3 Pump **IN**

5 Communication **COM**

2 Power supply

4 Alternative pump control **CTRL**

3.2.5 Internal view

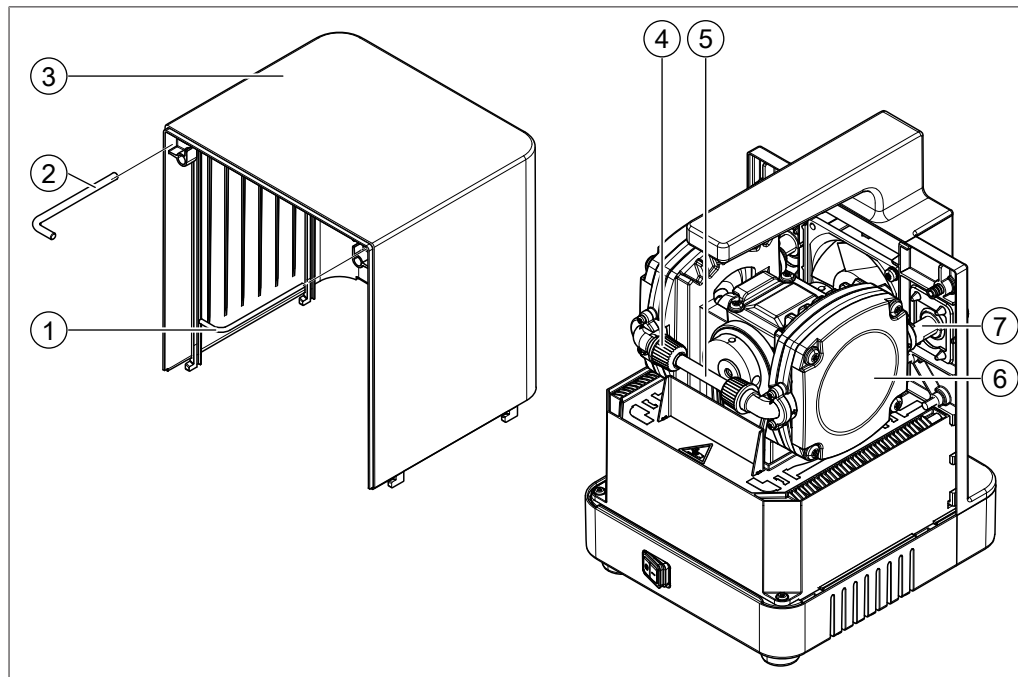

- | | |
|------------------------------|-------------------|
| 1 Torx key (TX10) | 2 Torx key (TX25) |
| 3 Pump cover | 4 GL14 cap nut |
| 5 Pump head connection piece | 6 Pump head |
| 7 Pump outlet | |

3.3 Scope of delivery



NOTE

The scope of delivery depends on the configuration of the purchase order.

Accessories are delivered as per the purchase order, order confirmation, and delivery note.

3.4 Type plate

The type plate identifies the instrument. The following type plate is an example. For more details refer to the type plate on the instrument.

The type plate is located at the rear of the instrument.

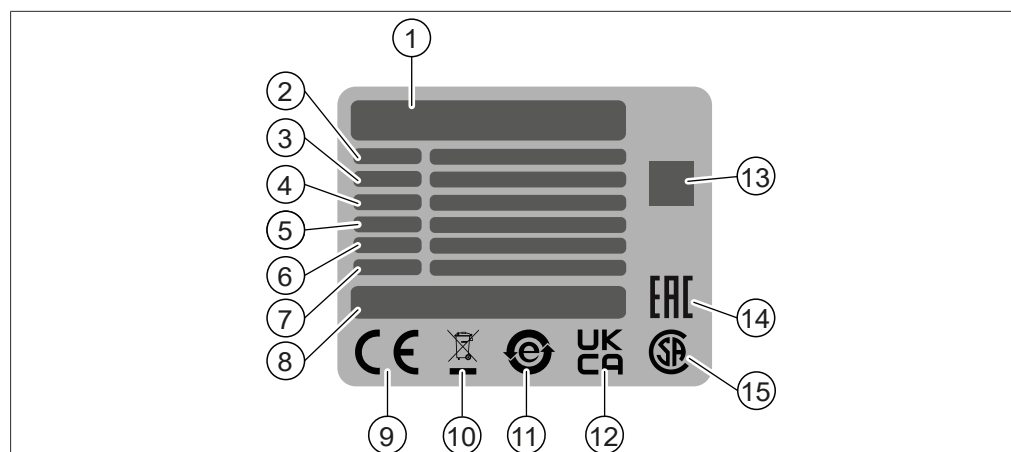

- | | | | |
|----|---|----|---|
| 1 | Company name and address | 2 | Instrument name |
| 3 | Serial number | 4 | Input voltage range |
| 5 | Frequency | 6 | Power consumption maximum |
| 7 | Year of manufacture | 8 | Product origin |
| 9 | Symbol for "CE conformity" | 10 | Symbol for "Do not dispose of as household waste" |
| 11 | Symbol for "electronics recycling" | 12 | Symbol for "UK Conformity Assessed" |
| 13 | QR-Code contains "Item number, Serial number" | 14 | Symbol for "Eurasian Conformity" (optional) |
| 15 | Symbol for "CSA certified" (optional) | | |

3.5 Technical data

3.5.1 Vacuum Pump

Specification	Vacuum Pump V-80	Vacuum Pump V-180
Dimensions (W × D × H)	185 mm × 207 mm × 238 mm	185 mm × 207 mm × 285 mm
Dimensions (W × D × H) with secondary condenser, interface and power plug	220 mm × 325 mm × 405 mm	220 mm × 325 mm × 405 mm
Weight	5.5 kg	5.6 kg
Connection voltage	100 – 240 VAC ± 10%	100 – 240 VAC ± 10%
Power consumption	180 W	180 W
Frequency	50 / 60 Hz	50 / 60 Hz
Overvoltage category	II	II
IP Code	IP21	IP21
Pollution degree	2	2
Terminal vacuum (absolute)	15 mbar	10 mbar
Pump capacity	1.3 m ³ /h	1.5 m ³ /h
Vacuum connection	GL-14	GL-14
Motor	Brushless DC motor	Brushless DC motor

Specification	Vacuum Pump V-80	Vacuum Pump V-180
Noise level	32 – 57 dBA 57 dBA with 100% load	32 – 57 dBA 57 dBA with 100% load
Minimum clearance on all sides	350 mm	350 mm
Certificate	CB , CE , UL/CSA	CB , CE , UL/CSA

3.5.2 Ambient conditions

For indoor use only.

Specification	Value
Max. altitude above sea level	2,000 m
Ambient and storage temperature	5 – 40 °C
Max. relative humidity	80% for temperatures up to 31 °C decreasing linearly to 50% relative humidity at 40 °C

3.5.3 Materials

Component	Material
Drive unit body	Aluminium
Housing	PBT

In contact with solvents

Component	Material
Hose barb seals	Silicone (standard), EPDM or FPM
Hose barb	PP
Vacuum tubing	EPDM / PP
Pump-head connection piece	FEP
Cap nut seals (GL-14)	EPDM
Non-return valve O-rings	FFKM
Pump heads	PPS
Membranes	PTFE / rubber
Valve plate	PEEK
Valve head	PEEK
Housing Silencer	PBT
Filtermat Silencer	PET

3.5.4 Installation site

The installation site must meet the following requirements:

- The installation site meets the safety requirements. See Chapter 2 "Safety", page 6
- The installation site meets the specifications according to the technical data (e.g. weight, dimension, minimum clearance on all sides, etc.). See Chapter 3.5 "Technical data", page 15.
- The installation site has a firm, level and nonslip surface.
- The installation site has no obstacles (e.g. water taps, drains, etc.).
- The installation site has an own mains outlet socket for the instrument.
- The installation site allows that the power supply can be disconnected at any time in case of an emergency.
- The installation site is not exposed to external thermal loads, such as direct solar radiation.
- The installation site has enough space that cables / tubes can be routed safely.
- The installation site has a fume extraction apparatus available or is set up inside a fume hood.
- The installation site meets the requirements for the connected devices. See related documentation.
- The installation site offers enough space, that the air from the fan can circulate.

4 Transport and storage

4.1 Transport



NOTICE

Risk of breakage due to incorrect transportation

- ▶ Make sure that the instrument is fully dismantled.
 - ▶ Pack all instrument components properly to prevent breakage. Use the original packaging whenever possible.
 - ▶ Avoid sharp movements during transit.
-
- ▶ After transporting, check the instrument and all glass components for damage.
 - ▶ Damage that has occurred in transit should be reported to the carrier.
 - ▶ Keep packaging for future transportation.

4.2 Storage

- ▶ Make sure that the ambient conditions are complied with (see Chapter 3.5 "Technical data", page 15).
- ▶ Wherever possible, store the instrument in its original packaging.
- ▶ After storage, check the instrument, all glass components, seals and tubing for damage and replace if necessary.

4.3 Lifting the instrument



NOTICE

Dragging the instrument can damage the feet of the instrument.

- ▶ Lift the instrument when positioning or re-locating.
-
- ▶ Lift the instrument at the points indicated.

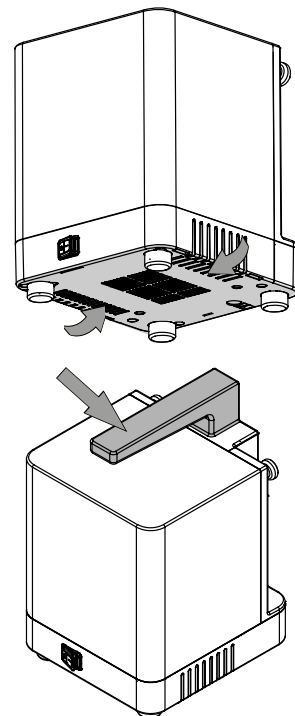

5 Installation

5.1 Before installation



NOTICE

Instrument damage due to switching it on too early.

Switching on the instrument too early after transportation can cause damage.

- ▶ Climatize the instrument after transportation.

5.2 Stacking the instrument



NOTE

It is only allowed to stack two vacuum pumps.

Precondition:

- The instrument is not connected.
- ▶ Remove the knurled-head screws.

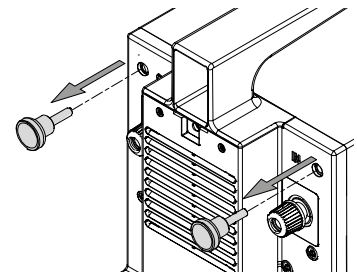

- ▶ Remove the pump top cover.

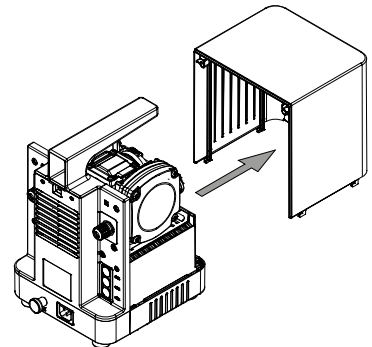

- ▶ Remove the screws.

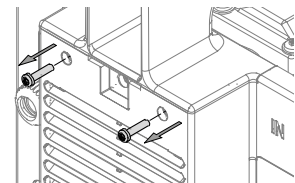

- ▶ Remove the plastic cover/carrying handle.

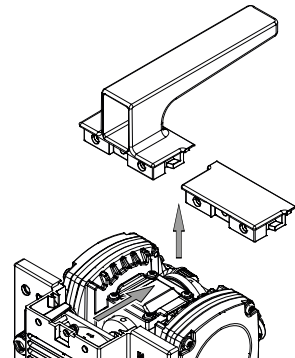

- ▶ Place the pump top cover.

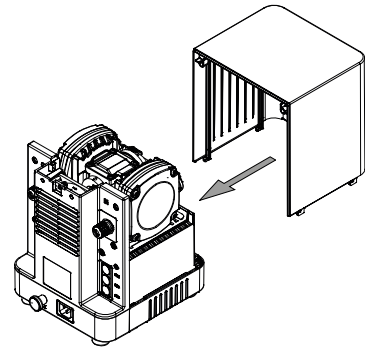

- ▶ Mount the knurled-head screws.

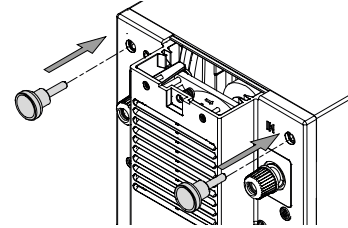

- ▶ Place the adapter plate on top.

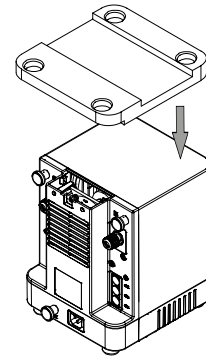

- ▶ Stack the instrument.

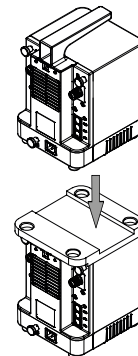

- ▶ Install and connect the instrument. See additional chapters according to delivered components.

5.3 Connecting the instrument

Precondition:

- The vacuum pump is installed.
- ▶ Install the vacuum hose onto the hose nipples.

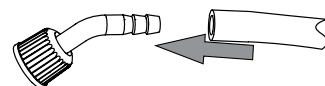

- ▶ Attach the vacuum hose to the vacuum pump connection **IN**.

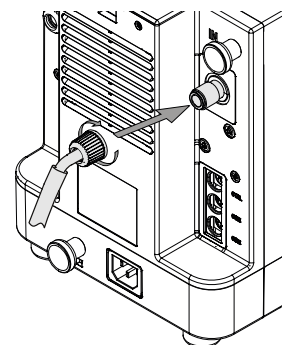

- ▶ Attach the silencer to the vacuum pump connection **OUT**.

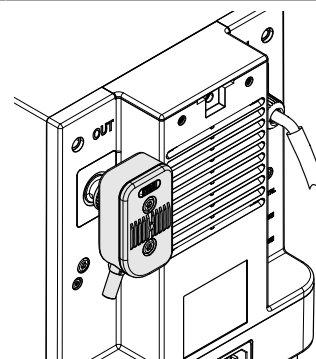

- ▶ Install and connect the instrument. See additional chapters according to delivered components.

5.4 Installing the Interface I-80 / I-180

- ▶ Installation of the Interface I-80 / I-180. See additional manual according to purchase order.



5.5 Connecting the BUCHI communication cable

Precondition:

- The vacuum pump is installed.
- ▶ Plug the communication cable into the vacuum pump.
- ▶ Connect the communication cable to the Rotavapor® or the Interface I-80 / I-180.

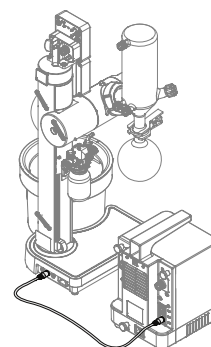
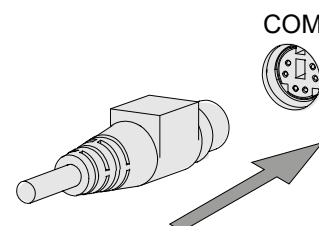

5.6 Accessories

5.6.1 Installing the Woulff bottle

The Woulff bottle is used to separate out particles and droplets and to equalize pressure.



NOTE

The Woulff bottle can also be installed on the Rotavapor®. See additional manual according to purchase order.

- ▶ Slide the mounting rail to the Woulff bottle holder.

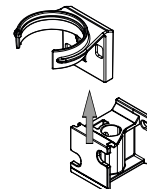

- ▶ Attach the vacuum tube and the cap to the Woulff bottle connection **PUMP**.

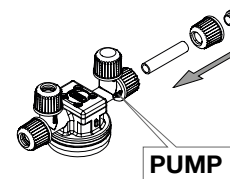

- ▶ Click the Woulff bottle into the Woulff bottle holder.

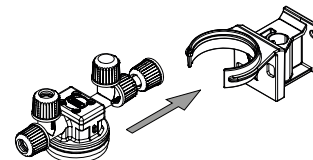

- ▶ Remove the screws.

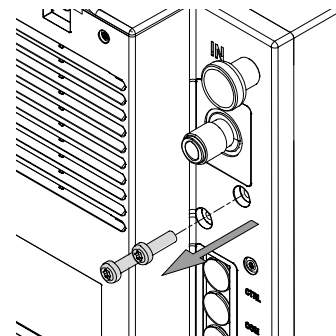

- ▶ Attach the vacuum tube to the vacuum pump connection **IN**.

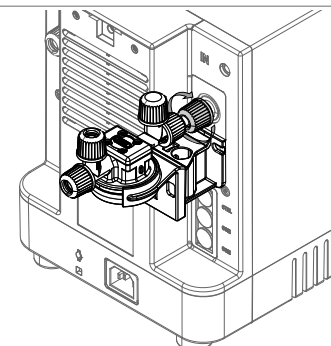

- ▶ Install the mounting rail with the screws.
- ▶ Tighten the screws.

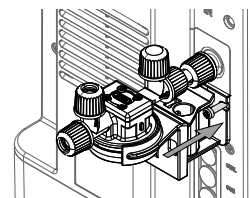

- ▶ Screw the glass part to the distributor cap. Make sure that the seal is in place.

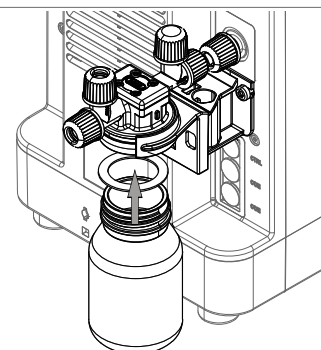

- ▶ Connect the instrument. See Chapter 5.6.2 "Connecting the Woulff bottle", page 23.

5.6.2 Connecting the Woulff bottle

- ▶ Install the vacuum hose onto the hose nipples.

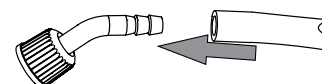

Precondition:

- The Woulff bottle is installed to the vacuum pump.
- The Interface I-80 / I-180 is installed.
- ▶ Attach the vacuum hose to the Woulff bottle connection **1**.

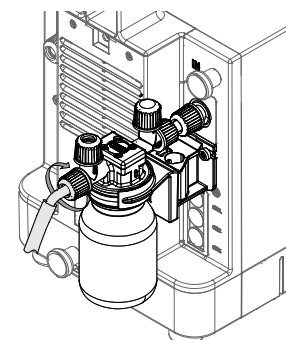

- ▶ Attach the vacuum hose to the condenser.

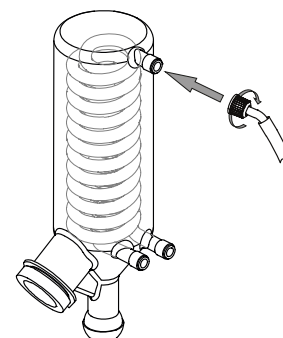

- ▶ Attach the vacuum hose to the Woulff bottle connection **CONTR.**

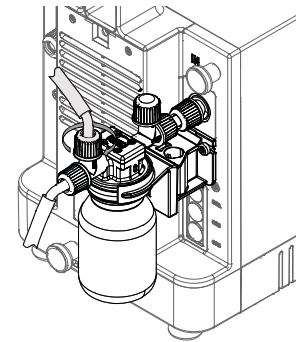

- ▶ Attach the vacuum hose to the Interface I-80 / I-180.

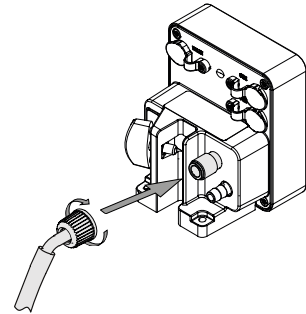

- ▶ Clamp the hose through the fixtures.

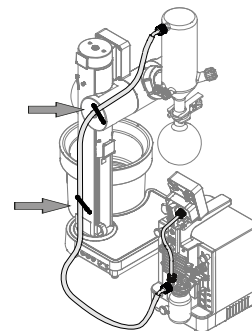

5.6.3 Installing the secondary condenser

Installing and connecting a secondary condenser at the pump outlet reduces the amount of residual vapors released to the surroundings.

- ▶ Attach the tube and the cap to the secondary condenser.

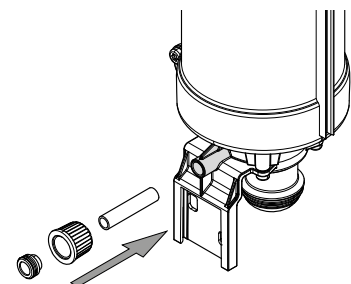

- ▶ Slide the mounting rail to the secondary condenser holder.

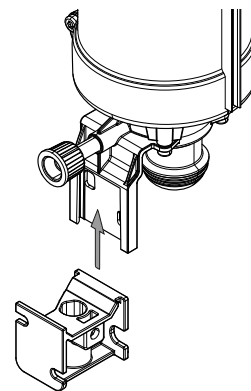

- ▶ Unscrew the screws.

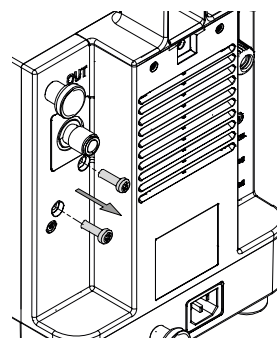

- ▶ Install the mounting rail with the secondary condenser by using the screws.
- ▶ Tighten the screws.

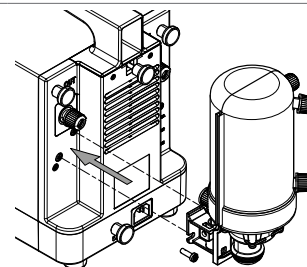

- ▶ Tighten the cap onto the vacuum pump connection **OUT**.

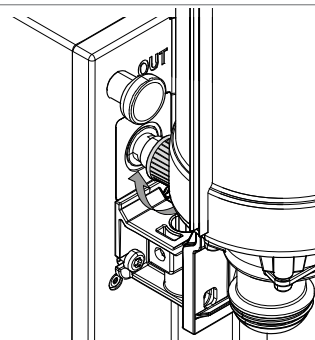

- ▶ Fit the receiving flask onto the condenser from below.
- ▶ Secure the receiving flask with the ball joint clamp.

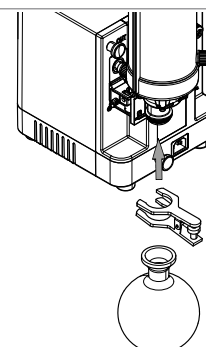

- ▶ Attach the silencer to the secondary condenser.
- ▶ Connect the secondary condenser. See Chapter 5.6.4 "Connecting cooling to the secondary condenser", page 26.

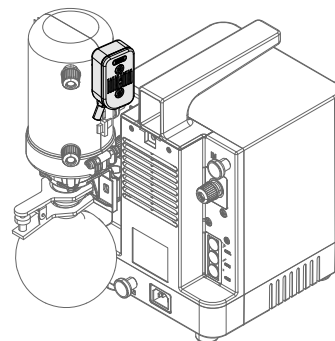

5.6.4 Connecting cooling to the secondary condenser

- ▶ Install the coolant hoses onto the hose nipples.
- ▶ Secure the coolant hoses in place with a hose clip.

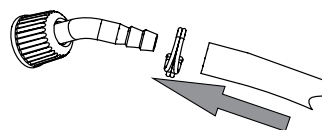

Precondition:

- The secondary condenser is installed to the vacuum pump.
- ▶ Attach the hose to the secondary condenser.

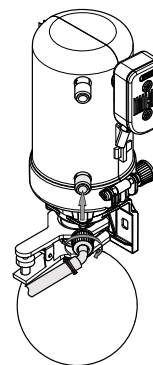

- ▶ Attach the hose to the condenser.

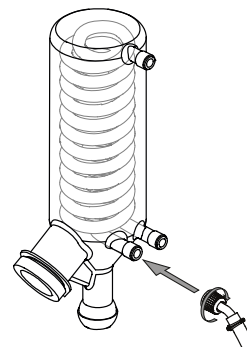

- ▶ Attach the hose to the secondary condenser.

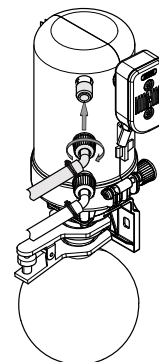

- ▶ Attach the hose to the cooling/chiller connection **IN**.

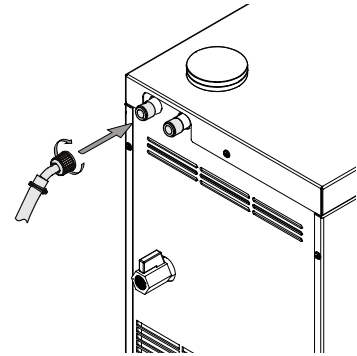

- ▶ Attach the hose to the cooling/chiller connection **OUT**.

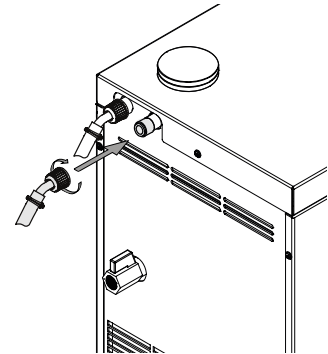

- ▶ Attach the hose to the condenser.

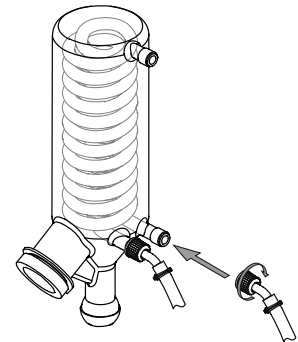

- ▶ Clamp the hose through the fixtures.

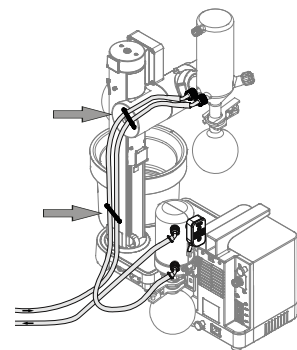

5.7 Securing against earthquakes

The instrument has an earthquake fixing point to protect the device against falling.

- ▶ Tie the lashing mount to a fixed point using strong cord or a wire.

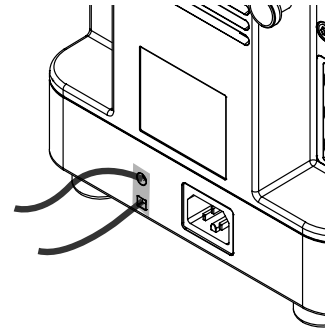

5.8 Establishing electrical connections



NOTICE

Risk of instrument damage because of not suitable power supply cables.

Not suitable power supply cables can cause bad performance or an instrument damage

- ▶ Use only BUCHI power supply cables.

Precondition:

- The electrical installation is as specified on the type plate.
- The electrical installation is equipped with a proper grounding system.
- The electrical installation is equipped with suitable fuses and electrical safety features.
- The installation site is as specified in the technical data. See Chapter 3.5 "Technical data", page 15.
- ▶ Connect the power supply cable to the connection on the instrument. See Chapter 3.2 "Configuration", page 10.
- ▶ Connect the mains plug to an own mains outlet socket.

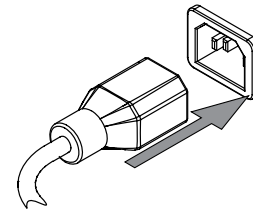

6 Operation

6.1 Operating without an interface

If not controlled by an interface, the vacuum pump runs in continuous mode.

Precondition:

- The vacuum pump is installed.
- ▶ Switch on the **main switch** to start the vacuum pump.
- ⇒ The pump starts running in continuous mode after some seconds.

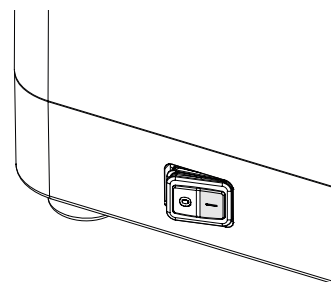

- ▶ Switch off the **main switch** to stop the vacuum pump.
- ⇒ The pump turns off.

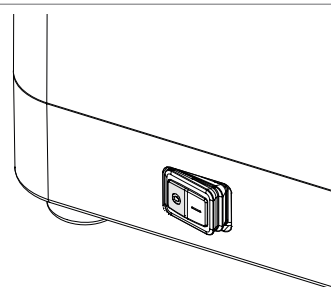

6.2 Operating with an interface

The vacuum pump can be controlled by the Interface I-80 or I-180. Control comprises the following parameters and functions, depending on the interface:

- Start/Stop the vacuum pump
- Setting the required vacuum
- Pump speed
- Timer

For more information about controlling the vacuum pump with an interface. See *Operation Manual Interface I-80 or Interface I-180*.

Precondition:

- The vacuum pump is installed.
- ▶ Switch on the **main switch**.

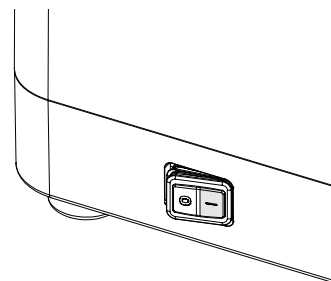

- ▶ Start the vacuum with the interface. See additional manual according to purchase order.



- ▶ Switch off the **main switch** to stop the vacuum pump.
- ⇒ The pump turns off.

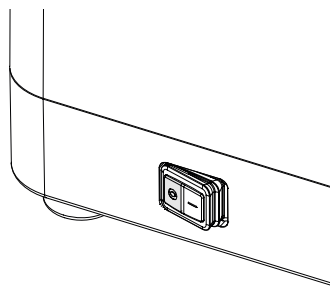

7 Cleaning and servicing



NOTE

Users may only carry out the servicing and cleaning operations described in this section.

Any servicing and repair work which involves opening up more than the casing front may only be carried out by authorized service technicians.

- ▶ Use only genuine BUCHI consumables and spare parts in order to ensure correct operation of the device and preserve the warranty.
- ▶ Before carrying out any servicing work, switch off the device and disconnect the power cable.

7.1 Maintenance work

Action	Daily	Weekly	Twice a year	Yearly	Additional information
7.4 Cleaning the pump after working with strong acids	1				only after working with strong acids
7.2 Cleaning the housing		1			
7.6 Cleaning the secondary condenser		1			
7.7 Cleaning the Woulff bottle		1			
7.5 Cleaning check valves, membranes and center tube			1		
7.10 Servicing the instrument			1		or when system is leaking
7.3 Cleaning the pump				1	or when system is leaking
7.8 Inspecting and replacing the seals				1	or when system is leaking
7.9 Inspecting and replacing the hoses				1	or when system is leaking

1 - Operator

7.2 Cleaning the housing

- ▶ Wipe down the housing with a damp cloth.
- ▶ If heavily soiled, use ethanol or a mild detergent.

7.3 Cleaning the pump

Dirt contamination of the pump heads is evidenced by the vacuum pump failing to achieve the terminal vacuum. Even though components are intact and the connections are air-tight.

Precondition:

- Instrument is switched off.
 - ▶ Disconnect the tubing connections.
 - ▶ Remove and clean the accessories, if installed.
 - ▶ Place a collecting vessel under the vacuum pump connection **OUT**.
 - ▶ Switch on the instrument.
 - ▶ Spray 10 mL ethanol or acetone into the vacuum pump connection **IN**.
 - ▶ Create a vacuum by closing the vacuum pump connection **IN**.
 - ▶ Release the vacuum by opening the vacuum pump connection **IN**.
 - ▶ Wait until the sound of the vacuum pump changes back to what it was before the ethanol or acetone was injected.
 - ⇒ Repeat the process four times.
 - ▶ Let the instrument run until there is no more liquid in the vacuum pump heads.
 - ⇒ Repeat the process if needed.
 - ▶ Switch off the instrument.
 - ▶ Reconnect the connections.
 - ⇒ Check if the terminal vacuum can be achieved.
 - ▶ If the terminal vacuum can not be achieved, the instrument has to be serviced. See Chapter 7.10 "Servicing the instrument", page 34.
-

7.4 Cleaning the pump after working with strong acids

After distilling strong acids or corrosive solutions the vacuum pump should be flushed out in order to increase its service life.

Precondition:

- Instrument is switched off.
 - ▶ Disconnect the tubing connections.
 - ▶ Remove and clean the accessories, if installed.
 - ▶ Place a collecting vessel under the vacuum pump connection **OUT**.
 - ▶ Switch on the instrument.
 - ▶ Pour 5 - 10 mL water into the vacuum pump connection **IN**.
 - ▶ Test the pH level of the water collected at the vacuum pump connection **OUT**.
 - ▶ Repeat the process until the discharged water has a pH level of between pH 3 and pH 9.
 - ▶ Run the instrument for two to three minutes to dry out.
 - ▶ Switch off the instrument.
 - ▶ Reconnect the connections.
-

7.5 Cleaning check valves, membranes and center tube

Dirt contamination is evidenced by the vacuum pump failing to achieve the terminal vacuum. Even though components are intact and the connections are air-tight.

Precondition:

- Instrument is switched off.
 - ▶ Disconnect the tubing connections.
 - ▶ Remove and clean the accessories, if installed.
 - ▶ Dismantle the pump heads. See Chapter 7.10 "Servicing the instrument", page 34.
 - ▶ Clean the check valves with a damp cloth.
 - ▶ Clean the membranes with a damp cloth.
 - ▶ Rinse out the center tube with water.
 - ▶ Re-assemble the pump heads.
 - ▶ Install and connect the instrument. See additional chapters according to delivered components.
-

7.6 Cleaning the secondary condenser

- ▶ Empty the receiving flask.
 - ▶ Spray ethanol into the air outlet of the condenser.
 - ▶ Rinse out the condenser.
 - ▶ Drain the ethanol from the bottom of the condenser.
 - ▶ To remove stubborn dirt (e.g. algae) from glass parts use an alkaline cleaning agent.
-

7.7 Cleaning the Woulff bottle

- ▶ Unscrew the glass part of the Woulff bottle.
- ▶ Clean the glass part with ethanol to remove residues.
- ▶ Make sure that the seal is in place.
- ▶ Screw the glass part back into the Woulff bottle distributor cap.

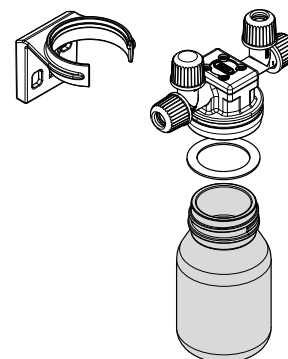

7.8 Inspecting and replacing the seals

- ▶ Remove the seals and inspect them for damages and cracks.
 - ▶ Rinse the intact seals with water or ethanol.
 - ▶ Dry the seals with a soft cloth.
 - ▶ Replace damaged seals.
 - ▶ Check the corresponding glass contact faces for damages (e.g. wear marks).
-

7.9 Inspecting and replacing the hoses

- ▶ Inspect the hoses for damages and cracks.
 - ▶ Replace damaged hoses.
-

7.10 Servicing the instrument



⚠ WARNING

Risk of electric shock

Electric shock from contact with live parts.

- ▶ Disconnect all electrical connections before servicing.



NOTICE

Risk of pump damage and loss of warranty entitlement

Unauthorized opening of the lower part of the pump can permanently impair the function of the pump.

- ▶ Only authorized BUCHI service technicians are allowed to open the lower part of the vacuum pump.

- ▶ Remove the knurled-head screws.

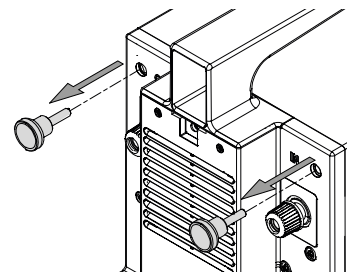

- ▶ Remove the pump top cover.

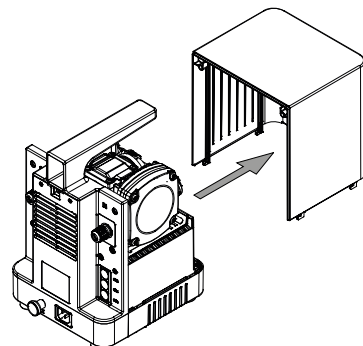

- ▶ Unscrew the caps of the center tube.

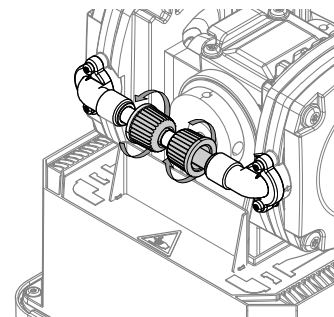

- ▶ Unscrew the pump head covers with the tool from the pump top cover.
- ▶ Remove the pump head covers.

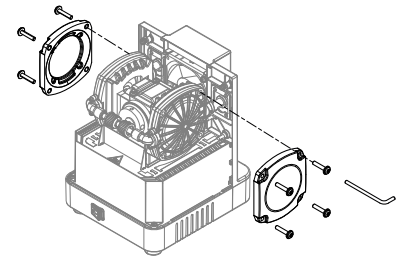

- ▶ Remove the rubber surrounds.

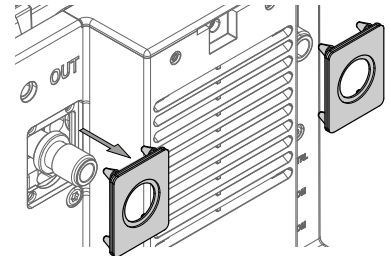

- ▶ Remove the pump heads.
- ▶ Remove the center tube.

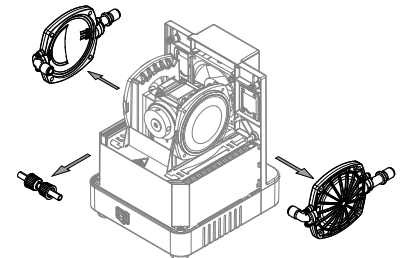

- ▶ Use the membrane clamp to loosen the membranes.
- ▶ Remove the membranes.
- ▶ Install the new membranes.
- ▶ Use the membrane clamp to tighten the membranes.

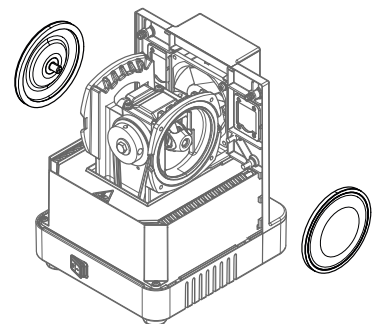

- ▶ Take the pump heads.
- ▶ Remove the screws from the pump head connection pieces.
- ▶ Replace the O-rings.
- ▶ Replace the check valves.

NOTICE! Pay attention to the orientation of the check valves.

- ▶ Reattach the connection pieces.

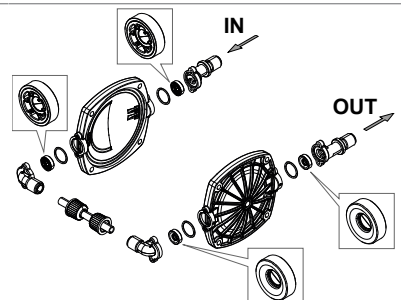

- ▶ Position the pump head covers.
- ▶ Position the center tube.

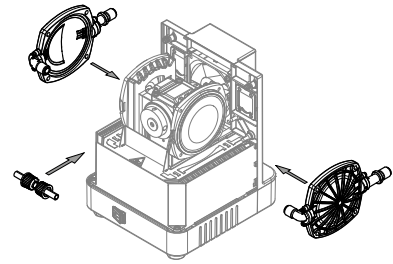

- ▶ Attach the rubber surrounds.

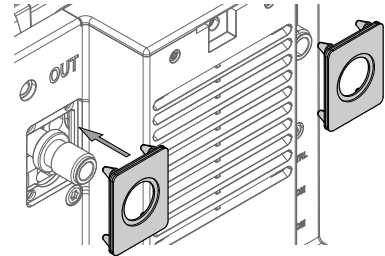

- ▶ Position the pump head covers.
- ▶ Tighten the screws.

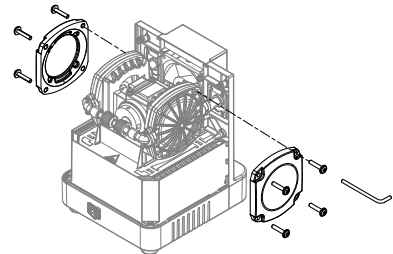

- ▶ Insert the new center tube (with caps and seals).
- ▶ Tighten the screw caps.

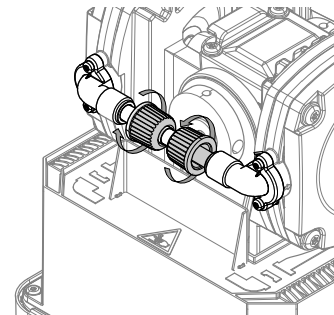

- ▶ Place the pump top cover.

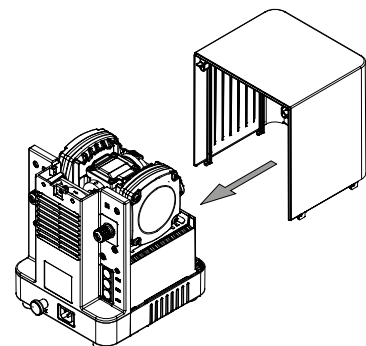

- ▶ Tighten the knurled-head screws.

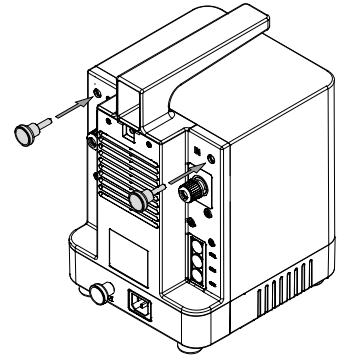

- ▶ Install and connect the instrument. See additional chapters according to delivered components.

8 Help with faults

8.1 Troubleshooting

Problem	Possible cause	Action
Instrument is not working	No electrical connection	▶ Establish an electrical connection. See Chapter 5.8 "Establishing electrical connections", page 28.
	Main switch is off	▶ Switch on the main switch.
	The pump OUT or a downstream device is blocked	▶ Make sure that all outlets are open.
Desired vacuum level is not reached	Connections are not correctly connected	▶ See Chapter 3.2.4 "Connections", page 13.
	Cap nuts and seals are not correctly fitted or are damaged	▶ Replace the seals. See Chapter 7.9 "Inspecting and replacing the hoses", page 33.
	Tubes or hoses are brittle and leaking	▶ Replace the tubing. See Chapter 7.9 "Inspecting and replacing the hoses", page 33.
	Membranes and check valves are dirty	▶ Clean the membranes and check valves. See Chapter 7.5 "Cleaning check valves, membranes and center tube", page 32. ▶ Replace the membranes and check valves. See Chapter 7.10 "Servicing the instrument", page 34.
	Check valve O-rings are leaking	▶ Replace O-rings. See Chapter 7.10 "Servicing the instrument", page 34.
Pump stops shortly after starting (in standalone operation)	Fan is defective	▶ Check the fan for blockage.
	Fan is blocked	▶ Contact BUCHI Customer Service.

8.1.1 Customer service

Only authorized service personnel are allowed to perform repair work on the instrument which is not described in this manual. Authorization requires a comprehensive technical training and knowledge of possible dangers which might arise when working at the instrument. Such training and knowledge can only be provided by BUCHI.

The customer service and support offers the following support:

- Spare part delivery
- Repairs
- Technical advice

Addresses of official BUCHI customer service offices can be found on the BUCHI website.

www.buchi.com

9 Taking out of service and disposal

9.1 Taking out of service

- ▶ Remove all solvents and coolants.
- ▶ Switch off the instrument and disconnect it from the mains power supply.
- ▶ Clean the instrument.
- ▶ Remove all tubing and communication cables from the device.

9.2 Disposal

The operator is responsible for proper disposal of the instrument.

- ▶ When disposing the equipment observe the local regulations and statutory requirements regarding waste disposal.
- ▶ When disposing, observe the disposal regulations of the materials used. For the used materials see Chapter 3.5 "Technical data", page 15 or the material labeling on the parts.

9.3 Returning the instrument

Before returning the instrument, contact the BÜCHI Labortechnik AG Service Department.

<https://www.buchi.com/contact>

10 Appendix

10.1 Spare parts and accessories







Use only genuine BUCHI consumables and spare parts in order to ensure correct, safe and reliable operation of the system.



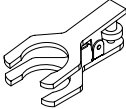

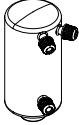

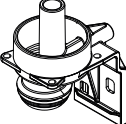
NOTE

Any modifications of spare parts or assemblies are only allowed with the prior written permission of BUCHI.

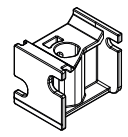
10.1.1 Spare parts

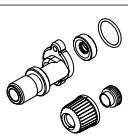

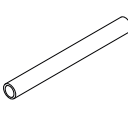
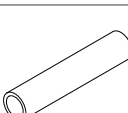
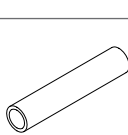
	Order no.	Image
Silencer	11080471	
Ball joint clamp. For BJ 35/20 To fasten receiving flask on condenser/secondary condenser.	003275	
Receiving vessel, GL 40, 125 mL, P+G For Woulff bottle	047233	
Secondary condenser V. Glass condenser Condenses remaining vapors after the vacuum pump outlet. Used with a recirculating chiller or tap water. Content: Secondary V condenser, cap nut GL14 (3 pcs.). Does not include holder and insulator.	11059902	
Secondary condenser V. Glass condenser, incl. Insulator, excl. Holder Condenses remaining vapors after the vacuum pump outlet. Used with a recirculating chiller or tap water. Content: Secondary V condenser, cap nut GL14 (3 pcs.) and condenser insulation. Does not include the holder.	11063841	
Support secondary condenser V. Incl. holder, EPDM seal, connection piece	11055584	
Support condenser V/C. Holder	047182	
Insulator. For secondary condenser (11059900) Insulation cover of the secondary condenser prevents condensation.	11059903	
Pump head For Vacuum Pump	11061577	

	Order no.	Image
Pump head, set. For Vacuum Pump Content: Pump head, set connection piece straight, set connection piece angled	11061578	
Mounting rail Adapter to mount the Woulff bottle or the secondary condenser to the pump or a lab stand.	11080481	
Woulff bottle holder	11075161	
Connection piece. Straight, for pump head Content: Connection straight, valve, O-ring, cap nut GL 14, EPDM seal	11061580	
Connection piece. Bent, for pump head Content: Connection bent, valve, O-ring, cap nut GL 14, EPDM seal	11061579	
Connection piece. FEP, Ø6/8 mm Center tube between the pump heads	047066	
Connection piece. FEP, Ø6/8 mm Tubing between secondary condenser and vacuum pump	047186	
Connection piece. FEP, Ø6/8 mm Tubing between Woulff bottle and vacuum pump	11059909	

10.1.2 Wear parts

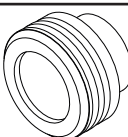
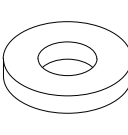
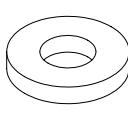
Seals

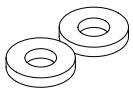







	Order no.	Image
Seal For cap nut GL14, EPDM seal	038225	
Seals, set. 10 pcs, for hose barbs GL 14, EPDM, black	040029	
Seals, set. 10 pcs, for hose barbs GL 14, FPM, green	040040	

	Order no.	Image
Seals, set. 10 pcs, for hose barbs GL 14, silicone, red	040023	
Seal Woulff bottle	047165	

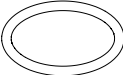
Hose barbs

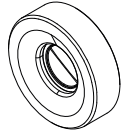
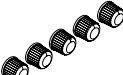
	Order no.	Image
Hose barb, bent, GL 14, incl. silicone seal	018916	
Hose barbs, set. 3 pcs, bent, GL 14, silicone seal Content: Hose barbs, seals.	041987	
Hose barbs, set. 4 pcs, bent, GL 14, EPDM seal Content: Hose barbs, cap nuts, seals.	043129	
Hose barbs, set. 4 pcs, bent, GL 14, FPM seal Content: Hose barbs, cap nuts, seals.	040295	
Hose barbs, set. 4 pcs, bent GL 14, silicone seal Content: Hose barbs, cap nuts, seals	037287	
Hose barbs, set. 4 pcs, straight, GL 14, EPDM seal Content: Hose barbs, cap nuts, seals.	043128	
Hose barbs, set. 4 pcs, straight, GL 14, FPM seal Content: Hose barbs, cap nuts, seals.	040296	
Hose barbs, set. 4 pcs, straight, GL 14, silicone seal Content: Hose barbs, cap nuts, seals	037642	
Hose barbs, set. 6 pcs, bent (4), straight (2), GL 14, silicone seal Content: Hose barbs, cap nuts, seals.	038000	

Further wear parts

	Order no.	Image
Membrane, set. 2 pcs, incl. support rings and membrane clamp Content: 2 membranes with support rings and 1 membrane clamp.	11065776	
Membrane, set. 10 pcs, incl. support rings and membrane clamp	11055214	
O-ring. For secondary condenser, FKM/FEP, Ø28.2/2.6 mm	11057661	
O-ring for check valve, set. 4 pcs, FFKM, Ø 15.4/1.55 mm	11057136	
Check valve, set. 4pcs, with O-rings	047156	
Check valve, set. 4 pcs, without O-rings	11058389	
Screw caps, set. 5 pcs, closed with PTFE seal, GL 14	040624	
Cap nuts, set. 10 pcs, screw cap with hole GL14, seal EPDM Content: Cap nuts, seals	041999	
Cap nuts, set. 10 pcs, screw cap with hole, GL 14	041956	
Set wear parts. Membranes, hose barbs Content: Membrane 2 pcs, support ring 2 pcs, check valve 4 pcs, connection piece, set seals 10 pcs, set hose barbs.	11062144	

10.1.3 Accessories



Secondary condenser

	Order no.	Image
Secondary condenser V incl. insulation, holder and 500 mL receiving flask Condenses vapor that goes through the pump, is cooled by cooling liquid	047180	

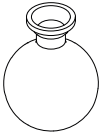
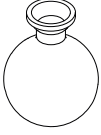
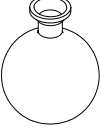
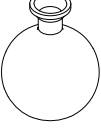
Receiving flask

	Order no.	Image
Receiving flask Glass, BJ 35/20, 250 mL	000423	
Receiving flask Glass, BJ 35/20, 250 mL, P+G	11060907	
Receiving flask Glass, BJ 35/20, 500 mL	000424	
Receiving flask Glass, BJ 35/20, 500 mL, P+G	025264	

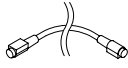
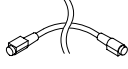
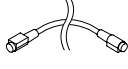
Communication cable

	Order no.	Image
Communication cable. BUCHI COM, 0.3 m, 6p	11058705	
Communication cable. BUCHI COM, 0.9 m, 6p	11070540	
Communication cable. BUCHI COM, 1.8 m, 6p	11058707	
Communication cable. BUCHI COM, 5.0 m, 6p	11058708	

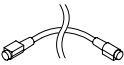
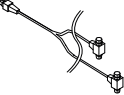
	Order no.	Image
Communication cable. BUCHI COM, 15 m, 6p	11064090	
Communication cable. Mini-DIN, Y-piece, with double-sided connectors, 2 m To connect 2 Rotavapor® systems with valve unit to 1 vacuum pump	11080283	

Tubing

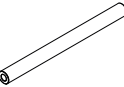
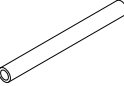
	Order no.	Image
Tubing, synthetic rubber, Ø6/13 mm, black, per m Use: Vacuum	11063244	
Tubing, silicone, Ø6/9 mm, transparent, per m Use: Cooling media	004133	

Other accessories

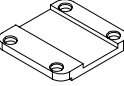
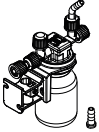
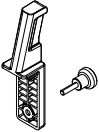
	Order no.	Image
Adapter plate For stacking vacuum pumps.	11074923	
Woulff bottle, 125 mL, P+G, incl. holder For trapping particles and droplets and for pressure equalization.	11075622	
Interface holder To install the Interface I-80 / I-180 on the Vacuum pump V-80 / V-180	11075588	



11594501 | A en

We are represented by more than 100 distribution partners worldwide.
Find your local representative at:

www.buchi.com

Quality in your hands
